

P. ARMSTRONG.
Gin-Saw Sharpener.

No. 213,158.

Patented Mar. 11, 1879.

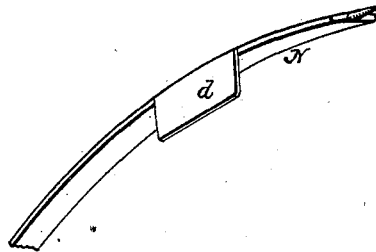
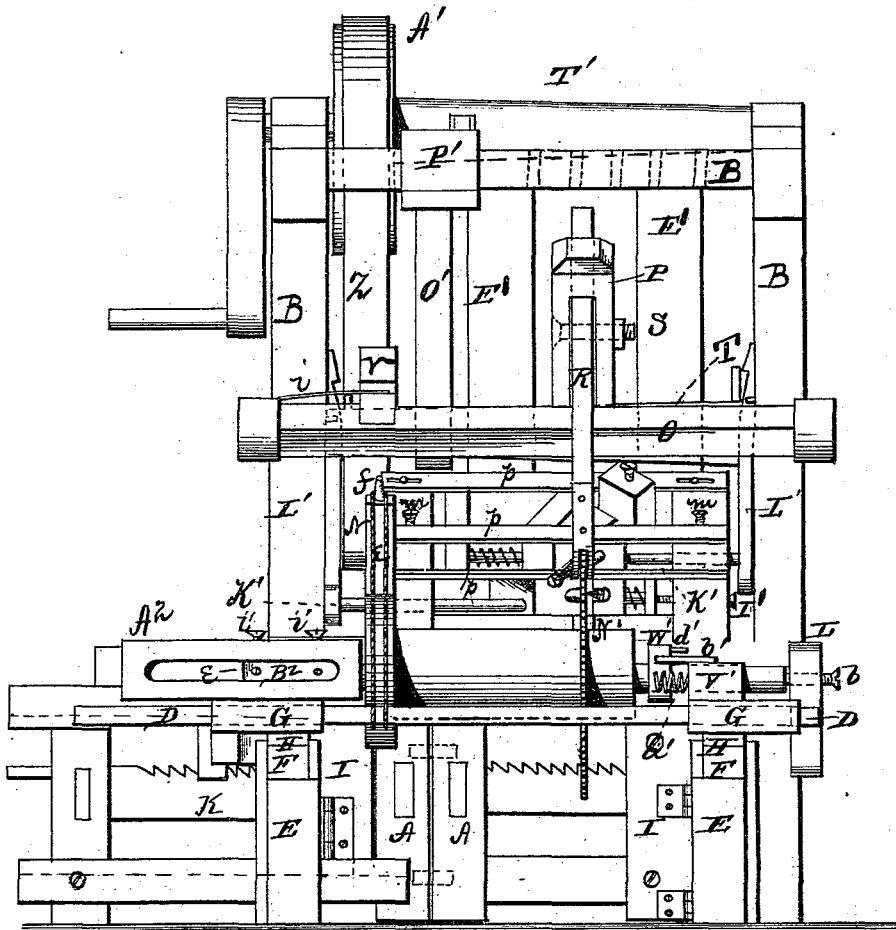

Fig. 2.



WITNESSES
F. L. Curran
Markhalt

By

INVENTOR
Pleasant Armstrong
Alexander Rector
Attorneys

P. ARMSTRONG.
Gin-Saw Sharpener.

No. 213,158.

Patented Mar. 11, 1879.

Fig. 3.

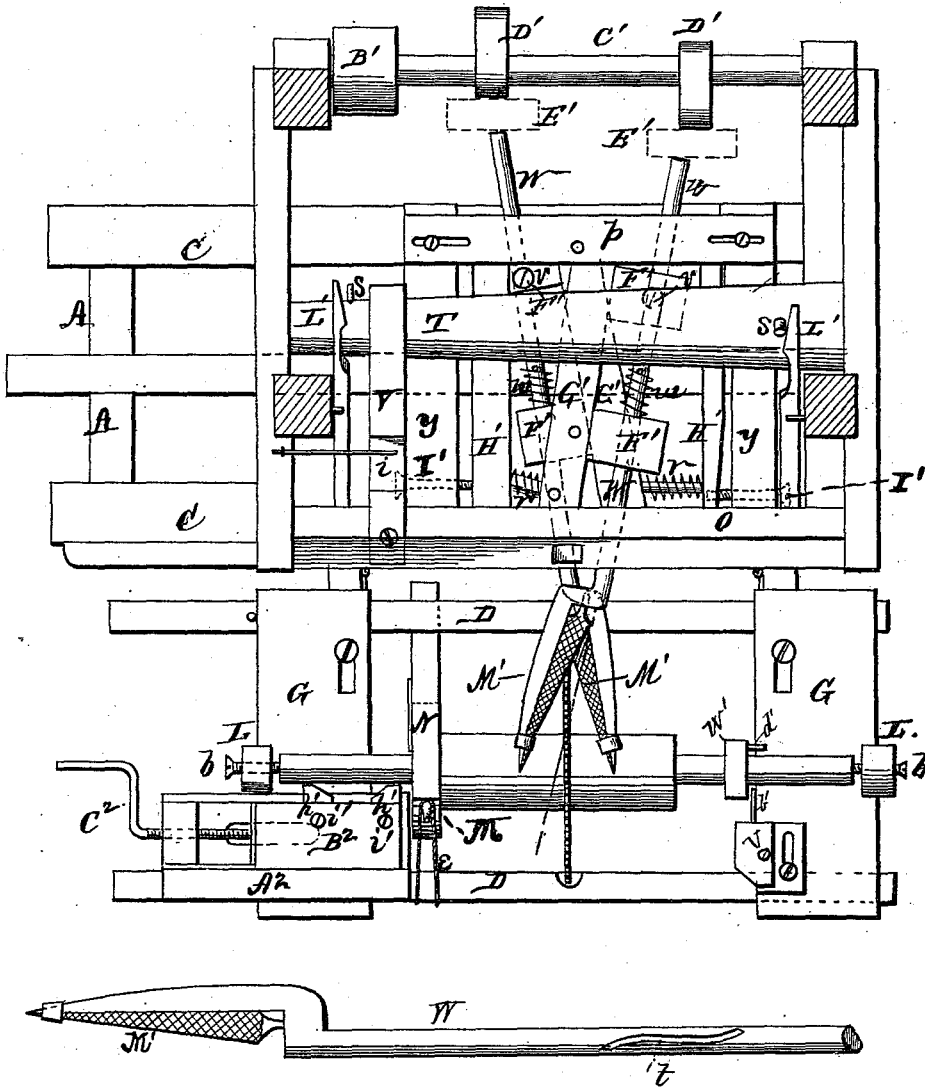

Witnesses.
F. L. Curand
Wankelt

Inventor,
Pleasant Armstrong
Alexander Munton
 Attorneys.

P. ARMSTRONG.
Gin-Saw Sharpener.

No. 213,158.

Patented Mar. 11, 1879.

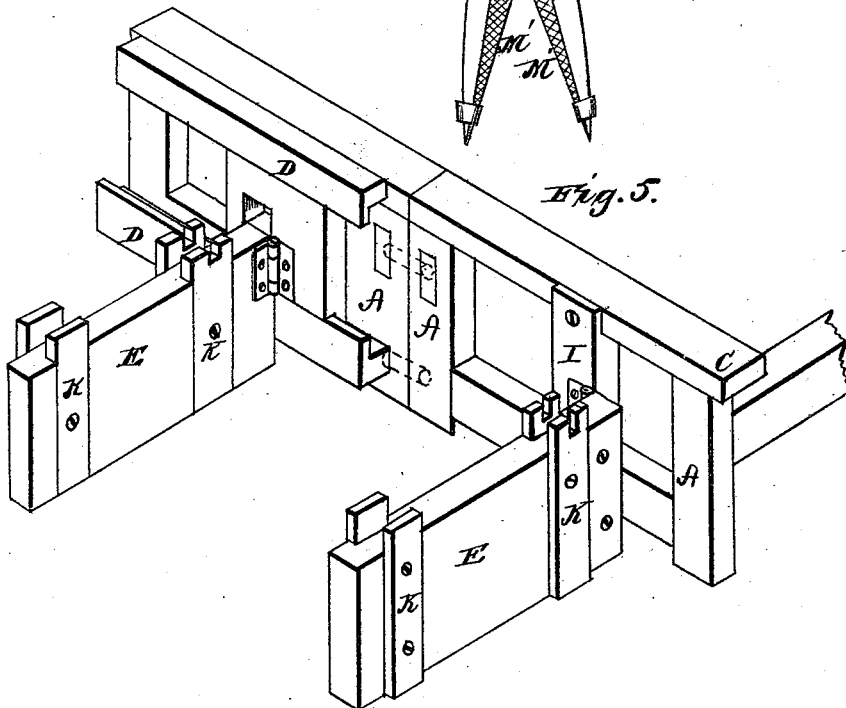
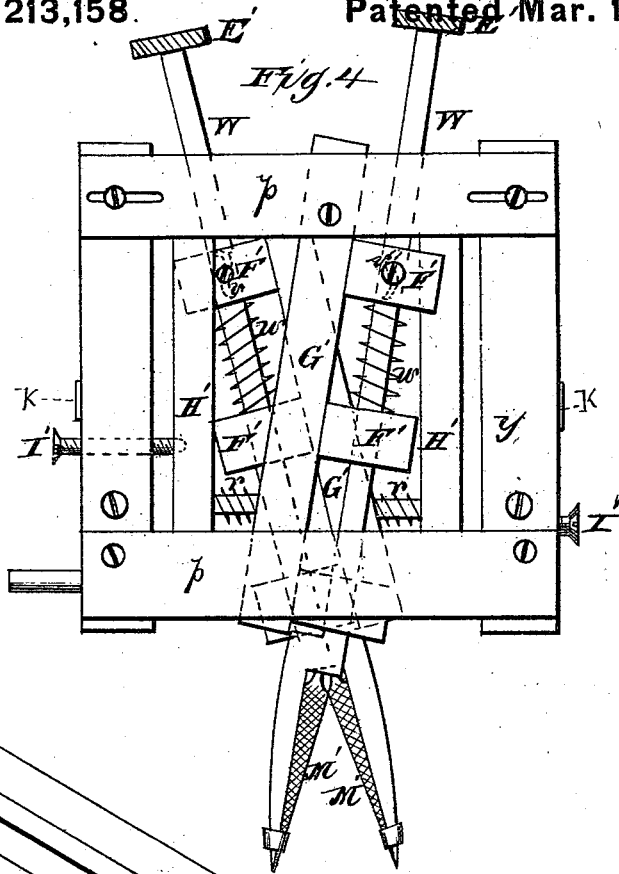

WITNESSES

F. L. Curand
H. A. Toulumin

INVENTOR

Pearson Armstrong
By his Attorneys *Alexander Watson*

UNITED STATES PATENT OFFICE.

PLEASANT ARMSTRONG, OF CAMDEN, ALABAMA.

IMPROVEMENT IN GIN-SAW SHARPENERS.

Specification forming part of Letters Patent No. 213,158, dated March 11, 1879; application filed June 26, 1878.

To all whom it may concern:

Be it known that I, PLEASANT ARMSTRONG, of Camden, in the county of Wilcox and in the State of Alabama, have invented certain new and useful Improvements in Gin-Saw Sharpeners; and do hereby declare that the following is a full, clear, and exact description thereof, reference being had to the accompanying drawings, and to the letters of reference marked thereon, making a part of this specification.

The nature of my invention consists in the construction and arrangement of a combined gin-saw sharpener and journal-turner, as will be hereinafter more fully set forth.

In order to enable others skilled in the art to which my invention appertains to make and use the same, I will now proceed to describe its construction and operation, referring to the annexed drawings, in which—

Figure 1 is a side elevation of my machine. Fig. 2 is a front elevation, and Fig. 3 a plan view, of the same. Fig. 4 is a plan view of the file-frame Y. Fig. 5 is a detailed perspective view of a part of the frame, with the slides and hinged horses.

A represents the bed-frame of the machine, to which the frame B is connected by grooves fitting over rails C C, which allow said frame B to be moved laterally for the purpose of shifting the files from one saw to the other. The frame B can also be entirely detached, if required. E is a horse, to which the lathe-bench G is connected. This lathe-bench is a frame that contains and sustains the gin while it is being sharpened and while its journals are being turned, or a gin-brush while its journals are being turned. D D are the rails, which extend from one end of the lathe-bench to the other, said rails being made fast in one head and loose in the other, so that the loose head can be extended to any desired length.

The horse E is by hinges attached to a slide, I, so that it can be adjusted to correspond with the contracted or extended length of the lathe-bench, which rests upon it.

F F are wedges, to be moved out or in for raising or lowering the bench G, so as to adjust the files to the angles of the teeth, which vary in different gins.

The lathe-bench G is attached to a wedge-

shaped bar, H, provided with an arm, J, which projects through a slot, *a*, in one of the uprights K, to prevent the bench from moving endwise while the wedge F moves it up or down.

On the outer side of each lathe-bench G is an arm, L, with screw-pivot *b* through its upper end, on which the journals revolve while being turned.

M is a gin-brush-driving pulley, on which is placed the brake N, to prevent any improper movement of a gin while its saws are being sharpened, said brake being provided with a flange, *d*, to keep the same from slipping off. The end of the brake N forms a pin, *f*, around which a cord, *e*, is passed, said cord being also passed around the rail D to hold the brake down on the pulley. The tension of the brake is regulated by wrapping the cord more or less times around the pin *f* on the end of the brake.

In the front part of the frame B is journaled the feed-shaft O, on which is a projecting arm, P, having two longitudinal slots at right angles to each other. In one slot is placed the feed-hand R, and in the other the screw S, that holds the same.

By adjusting the feed-hand higher or lower in the slot a longer or shorter stroke can be obtained, which is necessary, as some gins have longer teeth than others. The feed-hand is provided with a series of holes to admit of its adjustment, as described.

The feed-shaft obtains its motion by means of an arm or cam, *h*, attached to and projecting from the pulley T, and this arm or cam operates an arm or lever, V, secured to the feed-shaft, so that once during each revolution of the pulley T the feed-hand will be operated to act upon the saw and turn the same. As soon as the arm *h* has passed the lever V a spring, *i*, throws the parts back again to their former position.

W W represent the file-handles, which are contained in frames Y Y, hinged together by hinges *k* at or near the center, on each side, so as to allow the upper frame to oscillate, and thus, by the use of a screw, *m*, and spring *n*, as shown, elevate or depress the upper file, so as to adjust the same to the teeth of the saws after said teeth have been adjusted to

the lower file by means of the wedges $F F$, as above described. Z is a belt which runs from the driving-pulley A^1 to a pulley, B^1 , on a shaft, C^1 , at the rear of the machine. Upon this shaft C^1 are two eccentrics, $D' D'$, which revolve against and operate two suspended intermediate drivers, $E' E'$, which gives them a vibratory movement to push forward the file-handles, and said parts are brought back by springs on the file-handles, as hereinafter described.

Each file-handle W is passed through two, three, or more boxes, F' , which are attached to a bar, G' . The bars $G' G'$ and their boxes slide laterally between bars $p p$ in the frames $Y Y$, and are by said bars kept from moving forward or backward. The bars G' are pressed in opposite directions, so as to bring the files in proper position and with suitable pressure on the saw-teeth, by means of springs $r r$, and the tension of these springs is regulated by means of bars H' and set-screws I' , as shown.

Through the sides of the file-handle frames Y , at the front end, are passed slides K' , which bear against the front box, F' , for each file-handle, and each slide is operated by a lever, L' , to overcome the pressure of the spring r , for throwing out the files, so as not to touch the teeth while the saw is being turned.

The levers L' extend rearward over the pulley T , and their extreme rear ends are beveled, so as to be operated by lugs or cams $s s$ on said pulley, giving them the proper motion to operate the slides, as described.

Each file-handle W has a spiral groove, t , made in it, and a pin, v , in one of the boxes F' works in said groove, so as to give a rotary movement to the files.

To regulate the divergence of the files the rear bars, p , are slotted, so as to be adjusted laterally on the frames Y , it being understood that the rear ends of the bars G' are pivoted to said bars p . $w w$ are springs on the file-handles, to move them back after they have been moved by the cams D' .

$M' M'$ represent the files attached to the file-handles. These files are so arranged that the corners which work between the teeth are on a line with the center of the file-handles, so that while the grooves and pins in rotating the file-handles cause the front ends of said handles to move up and down, the corners of the files will remain in the same place, and this peculiar movement of the handle gives to the gin-teeth a needle shape.

N' represents a latch for holding the frames Y down in place. By releasing this catch the frames can be raised so as to lift the files above the top of a saw, ready to be moved to another.

The object of using the intermediate drivers E' in operating the file-handles is on account of the rotary movement, because as the handles go forward their rear ends get nearer together, which makes a sliding movement on the drivers. The file-handles diverge from parallel lines, and their ends do not work di-

rectly against the cams D' , because one is higher than the other, and hence it would require two shafts, while with the use of the intermediate drivers only one is required.

The pulley T receives its motion by a belt, O' , from a pulley, T' , above, the pulley A^1 being on the same shaft as this latter pulley T' , and operated by a crank or otherwise. The pulleys $T T'$ are conical or tapering in opposite directions, so that by shifting the belt O' it varies the speed of the feed. The belt is shifted by means of a shipper, P' , sliding on a perforated bar at the top part of the frame B . On the shipper is a pivoted lever, R' , with spring x and pin y . This pin is forced by the spring into one of the holes for holding the shipper.

The holes mentioned are to be numbered, so as to indicate the number of strokes that the files will make while the feed-hand makes one stroke.

In the construction of my machine I make the main frame A in two sections, which are united together by dowels, as shown at the bottom of Fig. 2, so as to be readily separated; and as the horses E are hinged to the slides I , it will readily be seen that the machine can be materially reduced in size for shipment.

On one of the lathe-benches G is attached a block, V' , with a spring, a' , and plate or bell, b' , connected thereto. Upon the journal of the gin is fastened a clamp, W' , having a projecting arm, d' , the motion of which depresses the spring a' , so that when it escapes it strikes against the plate or bell, and thus signals each revolution. A^2 represents a bed-plate, fastened to the lathe-bench G , and provided with a chisel-holder, B^2 , operated by a crank-screw, C^2 . In the holder are two chisels, $h' h'$, adjusted by means of back screws $e' e'$, and fastened when adjusted by top screws $i' i'$, as shown. This device is used for turning the journals of the gin-saws or gin-brush.

The main advantages of my machine are, briefly, as follows:

The rotary movement of the files, giving a fine needle shape to the teeth.

The arrangement for shipping off the files while the saw is in motion, instead of the teeth dragging between the files and getting filed and scratched on their sides as they pass.

The arrangement for varying the feed, so as to obtain any desired number of file-strokes to one of feed, so that, whether a saw is more or less dull, each tooth can be made sharp before the files leave it.

The signal by which it will be known with perfect accuracy when every tooth on a saw has been sharpened.

The brake by which any improper movement of a saw while being sharpened is prevented.

The bed-frame on which the machine-frame moves being made in as many sections as may be desired, and so constructed as to be easily attached or detached for convenience of transportation, and having the horses, upon which

